



12VDC, 5A UNINTERRUPTIBLE PSU

EP-PS12-5AM

DESCRIPTION & FEATURES

EP-PS12-5AM is a UPS power supply, its main output is 13.8V / 5A, while it also provides extra maximum 650mA charge current. The PSU is designed based on 50W level. It could be used for CCTV surveillance / access control / fire alarm and other security systems.

FEATURES

- High efficiency up to 88%, long life and high reliability
- Metal Case With Key-lock
- Protections: overload/overvoltage/shortcircuit/battery deep discharge
- Multifunction LED indicators
- Additional charge current, no delay battery boots up
- Patented design, wallmount installation
- Optional modules to extend the usages
 - CCTV Module
 - Access Control Module
 - Relay Alarm Module

SPECIFICATION & DIMENSION

INPUT	Voltage Range	190 - 265VAC	
	Frequency Range	50 - 60Hz	
OUTPUT	Voltage (DC Supplies)	13.8V	
	Voltage (BT Supplies)	Same as battery voltage	
	Rated Current	5A	
	Rated Power (Max)	80W (with charging)	
	Line Regulation	±2%	
	Load Regulation	±2%	
	Output Channel	1 Channel	
CHARGING	Voltage	13.8V	
	Current	800mA (max.)	
PROTECTION	Overload	6A ±5%	
		Hiccup, recovers automatically after fault condition is removed.	
	Over Voltage	16V ±5%	
		Hiccup, recovers automatically after fault condition is removed.	
	Short Circuit	Hiccup, recovers automatically after fault condition is removed.	
	Battery Deep Discharge	10V ±2%	
PSU shuts down until AC power recovers.			
Battery Reverse Connect	Battery does not work, no effect on main output.		
ENVIRONMENT	Temperature	Working: -20 - 50°C	Storage: -30 - 80°C
	Humidity	Working: 20 - 80%RH	Storage: 10 - 90%RH
LED INDICATOR	AC Power (Red)	On	AC power supplies
	Battery (Yellow)	On	Battery is fully charged
		Off	Battery is discharging
		Flickering	Battery is charging
DC Output (Green)	On	DC output supplies	
SAFETY & EMC	EMC Standards	EN 55032, EN 55035, EN 61000-3-2, EN 61000-3-3	
	LVD Standards	EN 62368-1-2014-A11-2017	
DIMENSION	Metal Box	330 x 265 x 75mm	

OPTIONAL MODULES

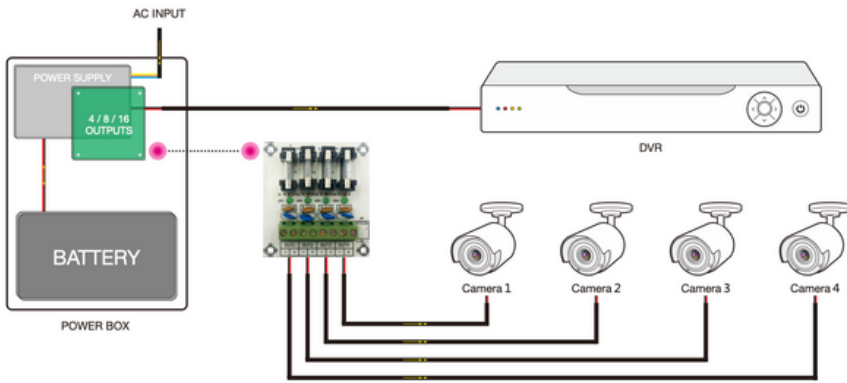

4 CHANNEL CCTV MODULE

- 4 SEPARATED FUSED OUTPUTS
- LED INDICATOR FOR EACH OUTPUT

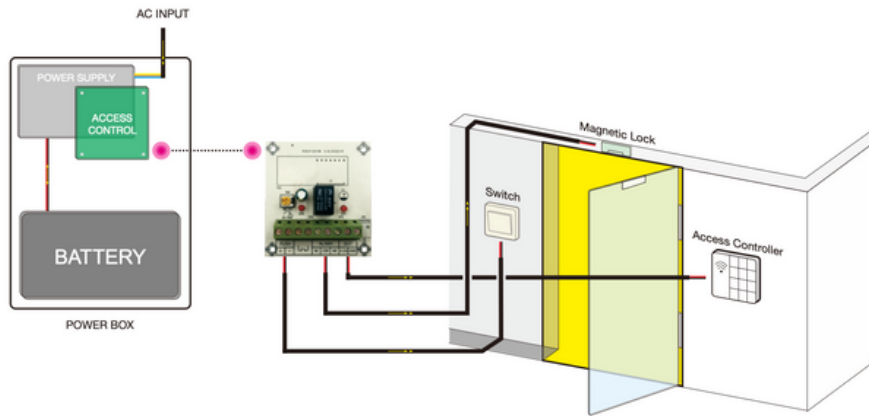
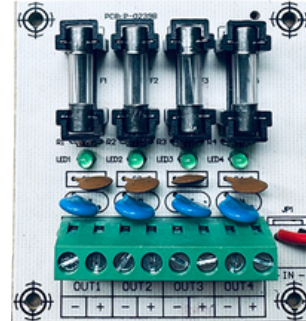

ACCESS CONTROL

- NC/NO/COM POWER OUTPUT
- TWO KINDS OF TRIGGER SIGNAL
- 0-10S ADJUSTABLE TIMER

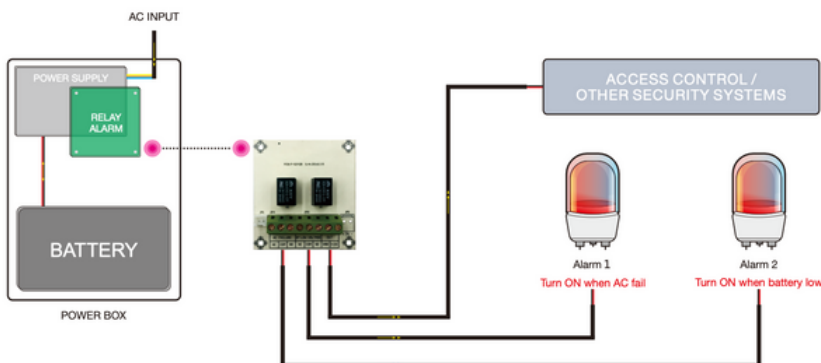
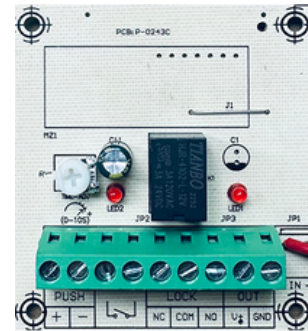

RELAY ALARM

- NC/NO/COM SIGNAL OUTPUT
- AC FAILURE ALARM
- BATTERY VOLTAGE LOW ALARM

