



# TOUCHLESS SENSOR EXIT BUTTON

CLOUD-BASED ACCESS CONTROL SYSTEM | MOBILE ACCESS

EP-NTB100W



MODEL :	EP-NTB100W
DIMENSIONS :	80(L) X 32(W) X 23(H) MM
POWER :	DC12-24V
OUTPUT CONTACT :	NO/NC/COM
MECHANICAL LIFE :	500,000 TESTED
MOUNTING WAY :	SURFACE MOUNT
MATERIAL :	ABS
WEIGHT :	0.045KG
OPERATING TEMPERATURE :	-20OC~+55OC (14~131F)
OPERATING HUMIDITY :	0~95% (RELATIVE HUMIDITY)
SENSITIVE DISTANCE :	5-20CM (ADJUSTABLE)
LED INDICATOR :	BLUE LED (STANDBY)/GREEN LED (ACTIVE)
TIME DELAY :	0.3~30S

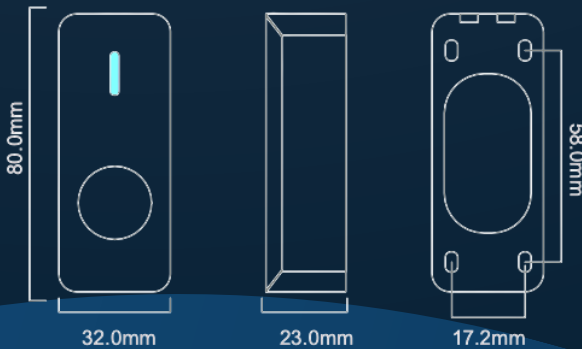

CLOUD-BASED ACCESS CONTROL SYSTEM | MOBILE ACCESS

© 2021 BY NUVEQ SDN BHD | ALL RIGHTS RESERVED

