

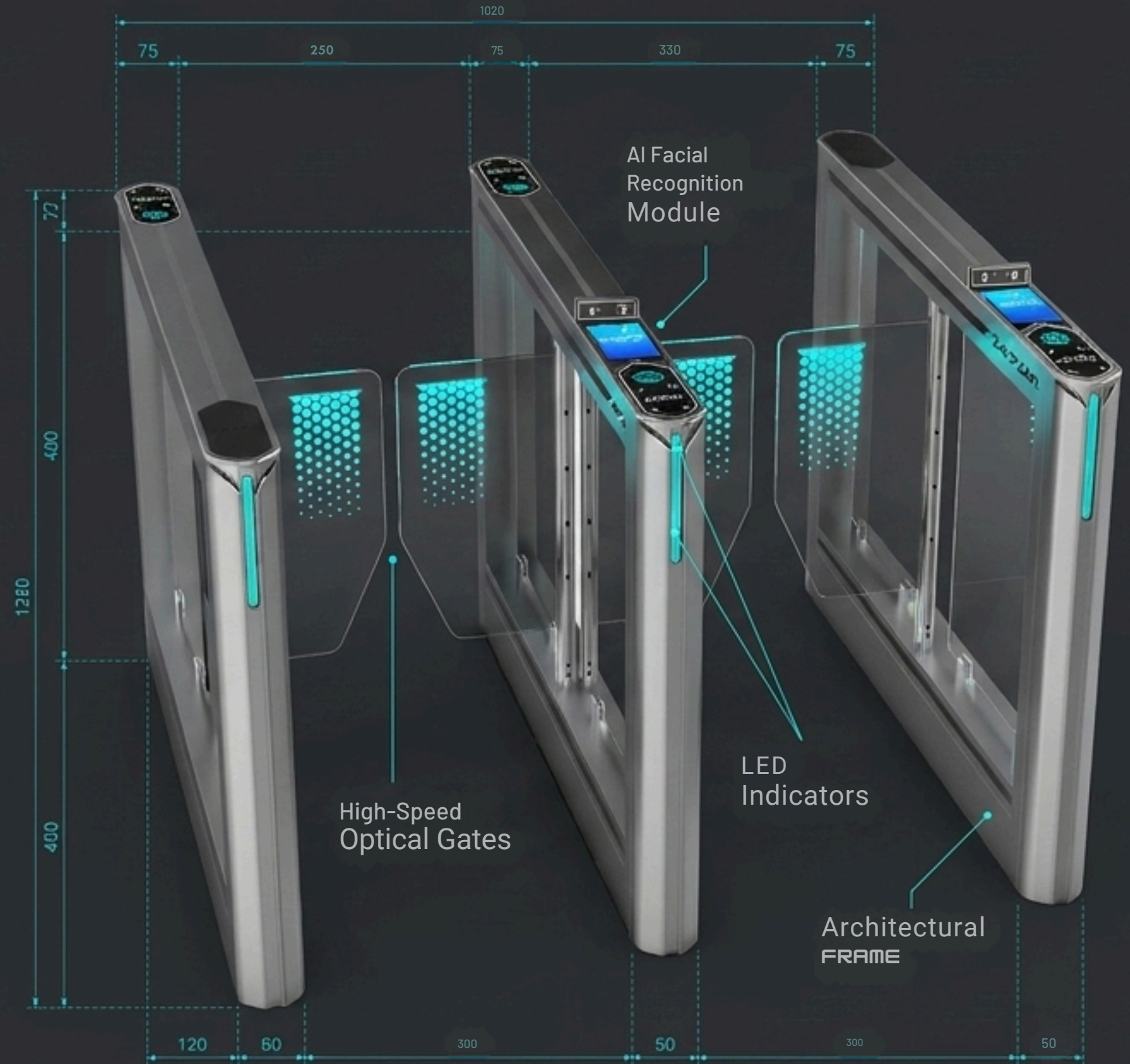

# Intelligent Access, Architecturally Refined.

The NUVEQ EP-SB200FR Optical  
Swing Gate with Embedded  
AI Facial Recognition.



# The Zero-Compromise Approach to Modern Facility Access.

Modern smart facilities—from commercial buildings to hospitals—demand entry management that eliminates bottlenecks without sacrificing security or architectural design.

## Secure

AI-powered dual-camera facial recognition and advanced multi-point infrared tracking.



## Efficient

Whisper-quiet operation driving a high-throughput flow of 60 persons per minute.



## Aesthetic

Premium CNC-machined aluminum alloy that complements high-end lobbies.

# Precision CNC Machining Meets Architectural Elegance



## Top Interface

10mm thick top cover enclosing the 7-inch capacitive display.

## Main Chassis

Premium aluminum alloy framework with sandblasted anodized finishing. 4-8mm thick body construction.

## Barrier Arms

Transparent Plexiglas swing arms for a sleek, unobtrusive profile.

## Dimensions

L1400 x W120 x H1000 mm footprint designed for seamless lobby integration.



## The Intelligent Core.

### Operating Power

Embedded Linux platform running on 1GB RAM with 8GB secure data storage for lightning-fast, localized access processing.

### Vision System

Dual 2MP binocular camera utilizing Wide Dynamic Range (WDR) imaging for precise recognition across varying lobby lighting conditions.

### Database Capacity

1:N recognition mode capable of seamlessly handling up to 50,000 distinct face templates locally.

### User Interface

High-visibility 7-inch capacitive display (1024 x 600 resolution).

# A universal hub for multi-modal access credentials.

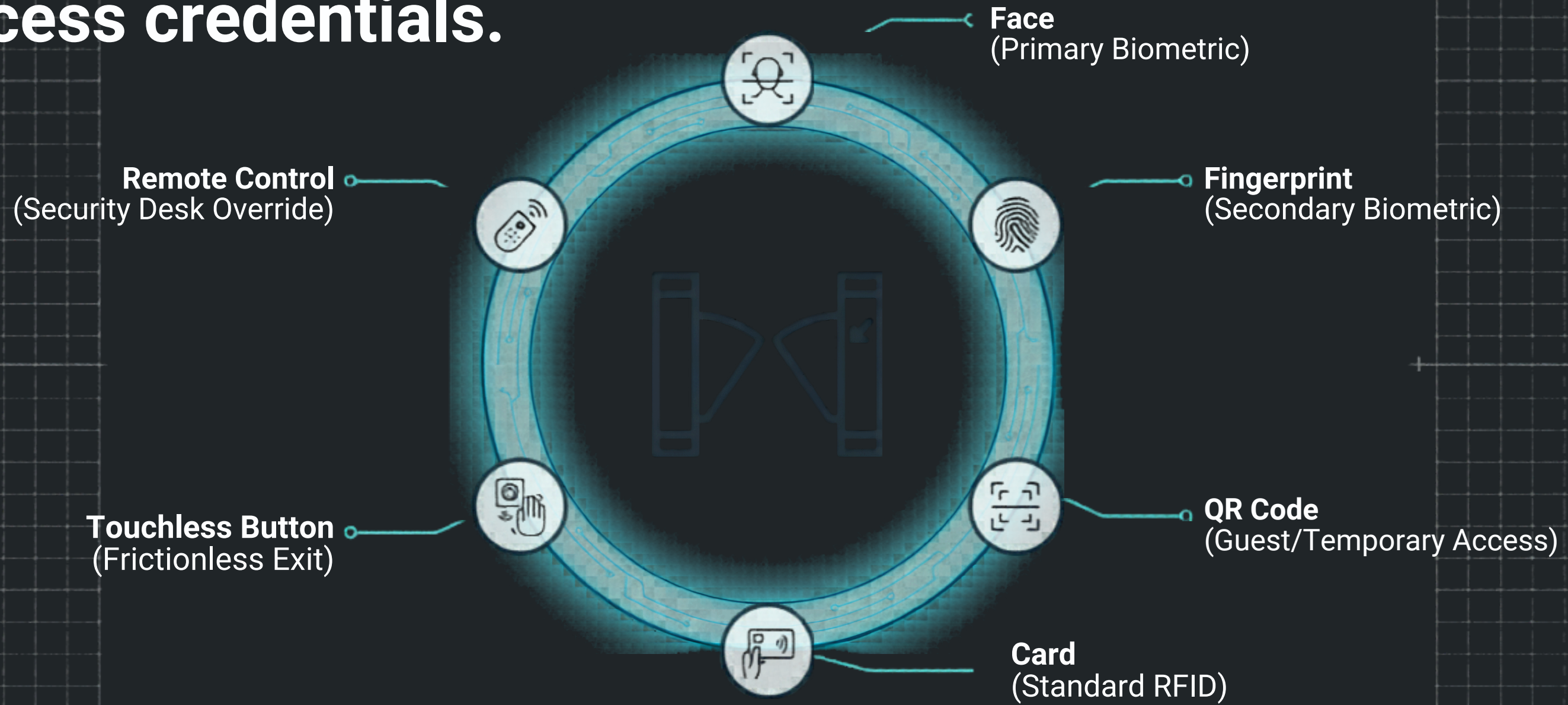

Operates seamlessly in bi-directional or single-directional workflows, integrating with any localized access control ecosystem.

Notebook-LM

# Dynamic Infrared Protection Matrix

Standard 6 pairs of infrared sensors (expandable to 10 pairs) create an active detection grid.

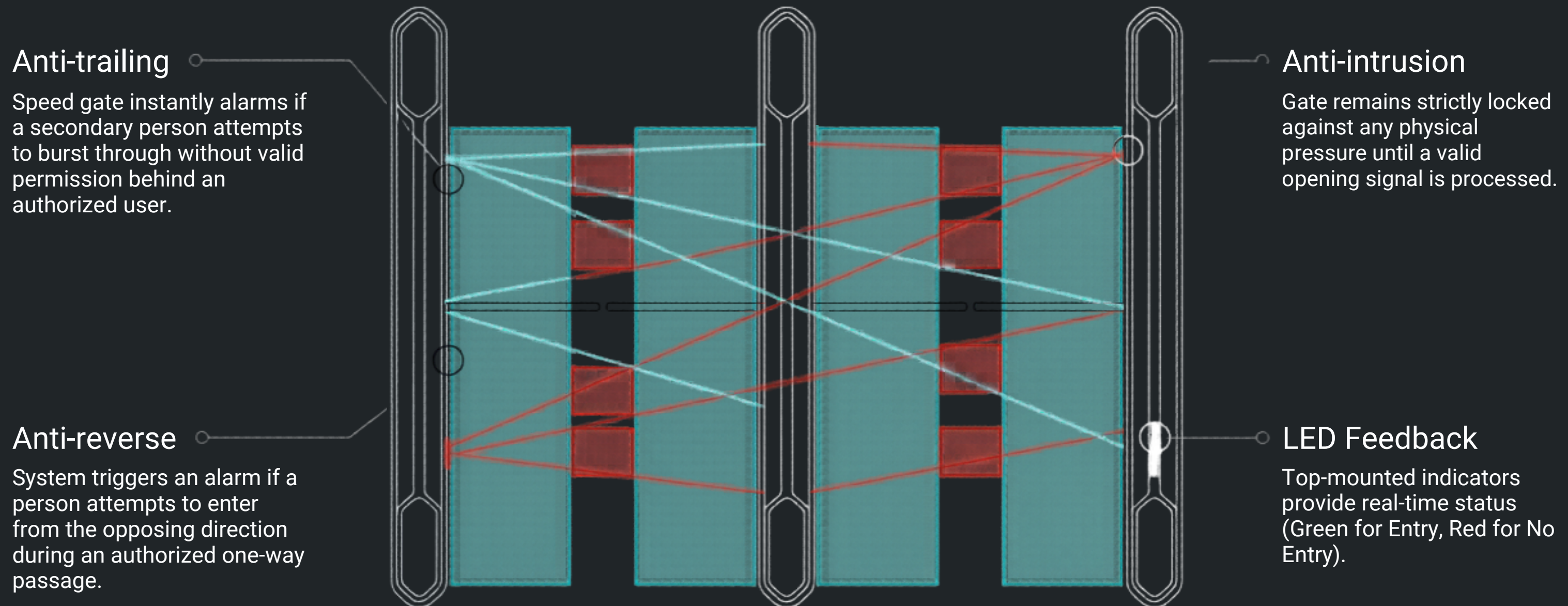

# High-Volume Throughout Engineering

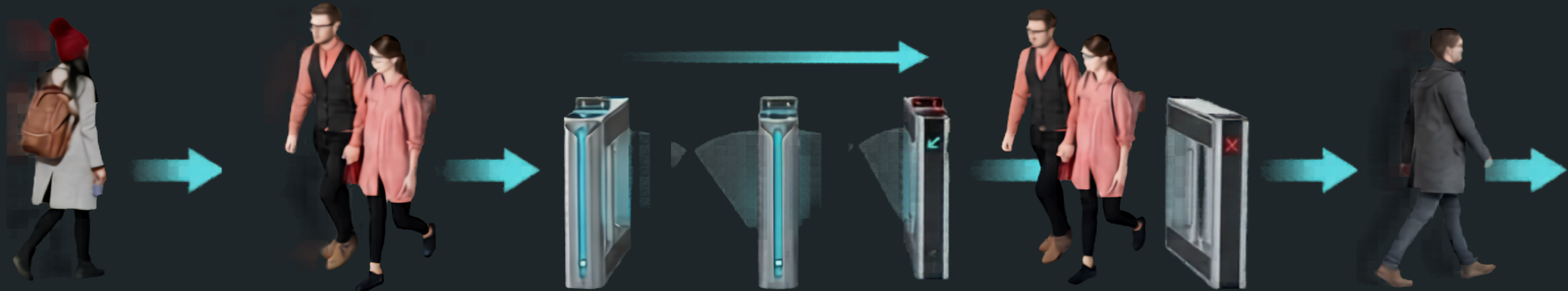

**0.5** Seconds 

High-performance brushless motor enables an ultra-fast gate opening speed (adjustable from 0.5 to 2 seconds).

**60** Persons / Min 

Continuous, smooth system flow prevents peak-hour lobby bottlenecks.

**10** Million MCBF 

High-durability motor mechanism engineered for maintenance-friendly, long-term operation.

# Engineered for Universal Compliance.

## ADA & Accessibility

**Standard Lane:**  
600mm passage width.

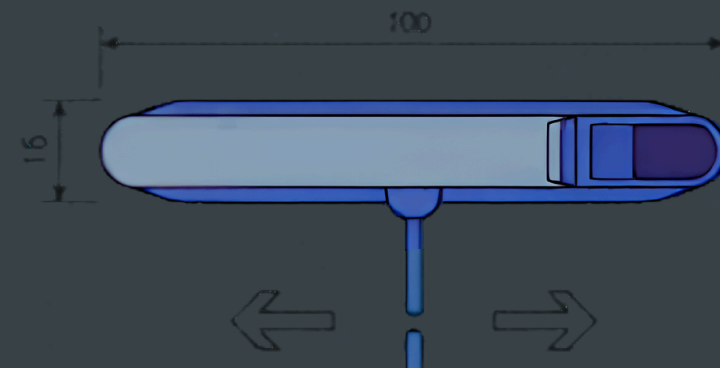

**Handicap / Wide Lane:**  
Seamlessly expandable up to 1000mm accommodate wheelchairs and heavy cargo. Both one-way and bi-directional passing supported.

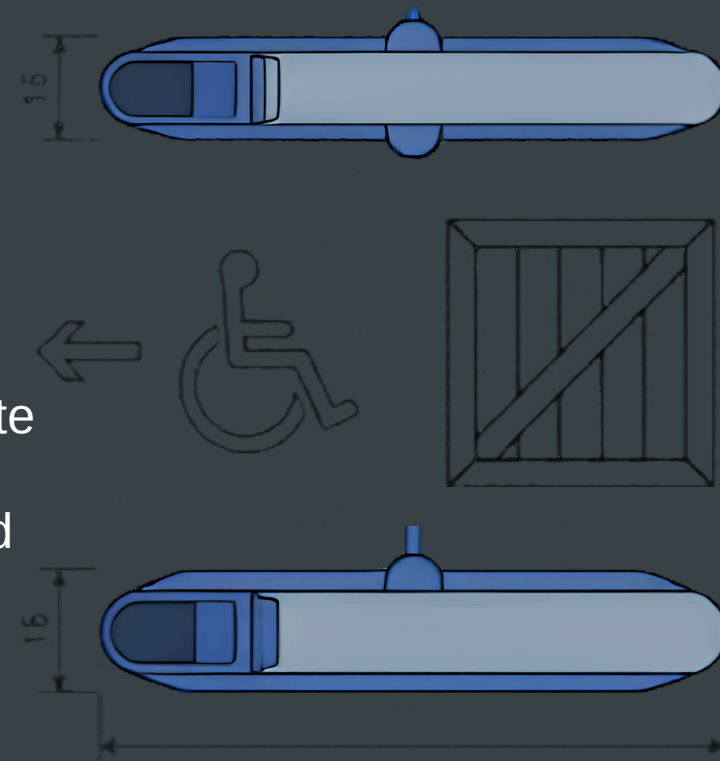

600mm  
passage width

Seamlessly  
expandable up to  
1000mm

## Fire Life Safety & Environment



### Failsafe Evacuation:

Arms automatically unlock and open during a power failure, ensuring strict fire safety emergency compliance.

### Intuitive Routing:

Distinct top-mounted LED indicators (Green = Entry, Red = No Entry).

### Environmental:

RoHS Certified and low power consumption (200W).



# Technical Blueprint & Dimensional Data.

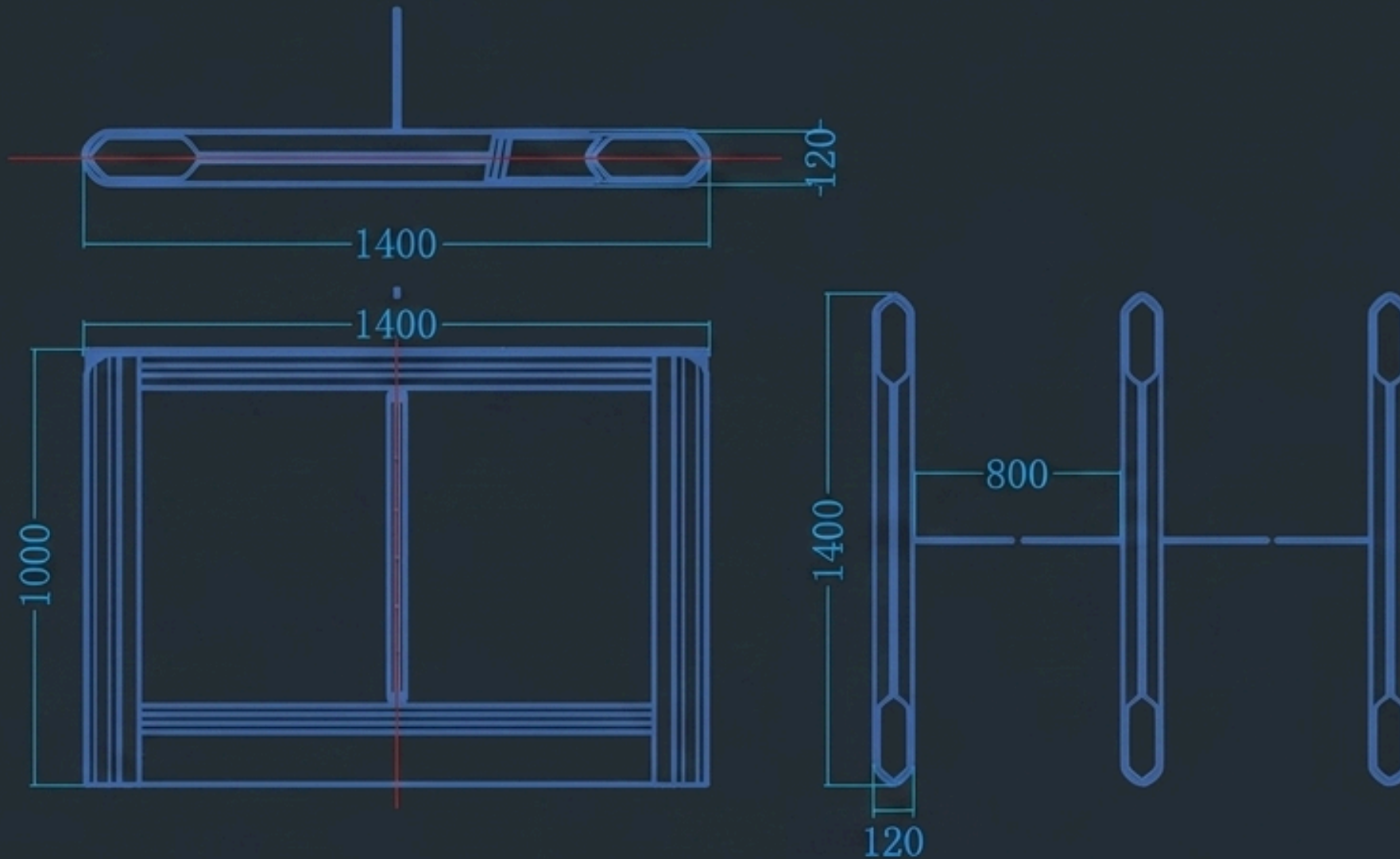

<b>Model:</b>	EP-SB200FR
<b>Dimensions:</b>	L1400 × W120 × H1000 mm
<b>Power Supply:</b>	AC110V - 220V
<b>Operating Temp:</b>	-15°C to +70°C
<b>Operating Humidity:</b>	Relative humidity <95% (without condensation)

# Engineered for Every Modern Hub.

The ultimate convergence of heavy-duty mechanical engineering and AI-driven spatial intelligence.

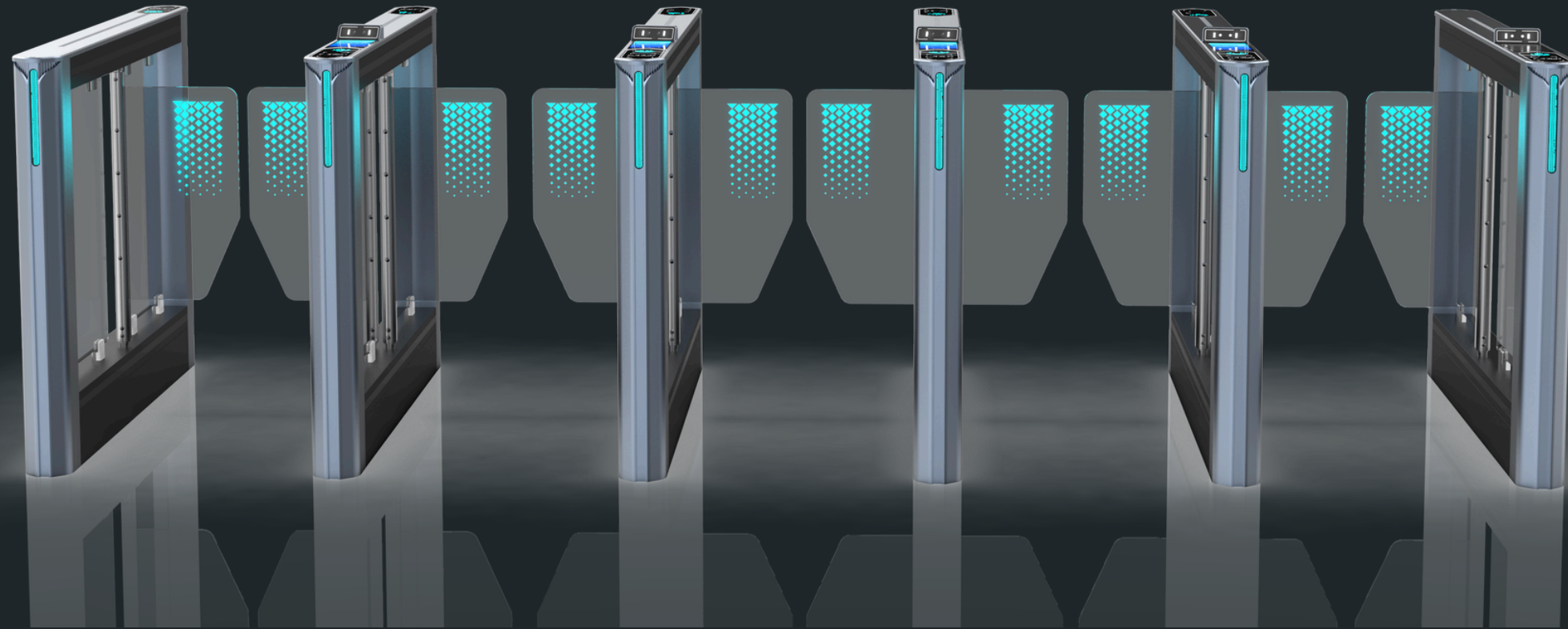

Commercial  
Buildings

Smart  
Factories

Condominiums

Hospitals

NUVEQ SDN BHD | [sales@nuveq.net](mailto:sales@nuveq.net) +603 9131 0918  
29, Jalan BS 7, Taman Bukit Segar, 43200 Cheras,  
Selangor, Malaysia.